

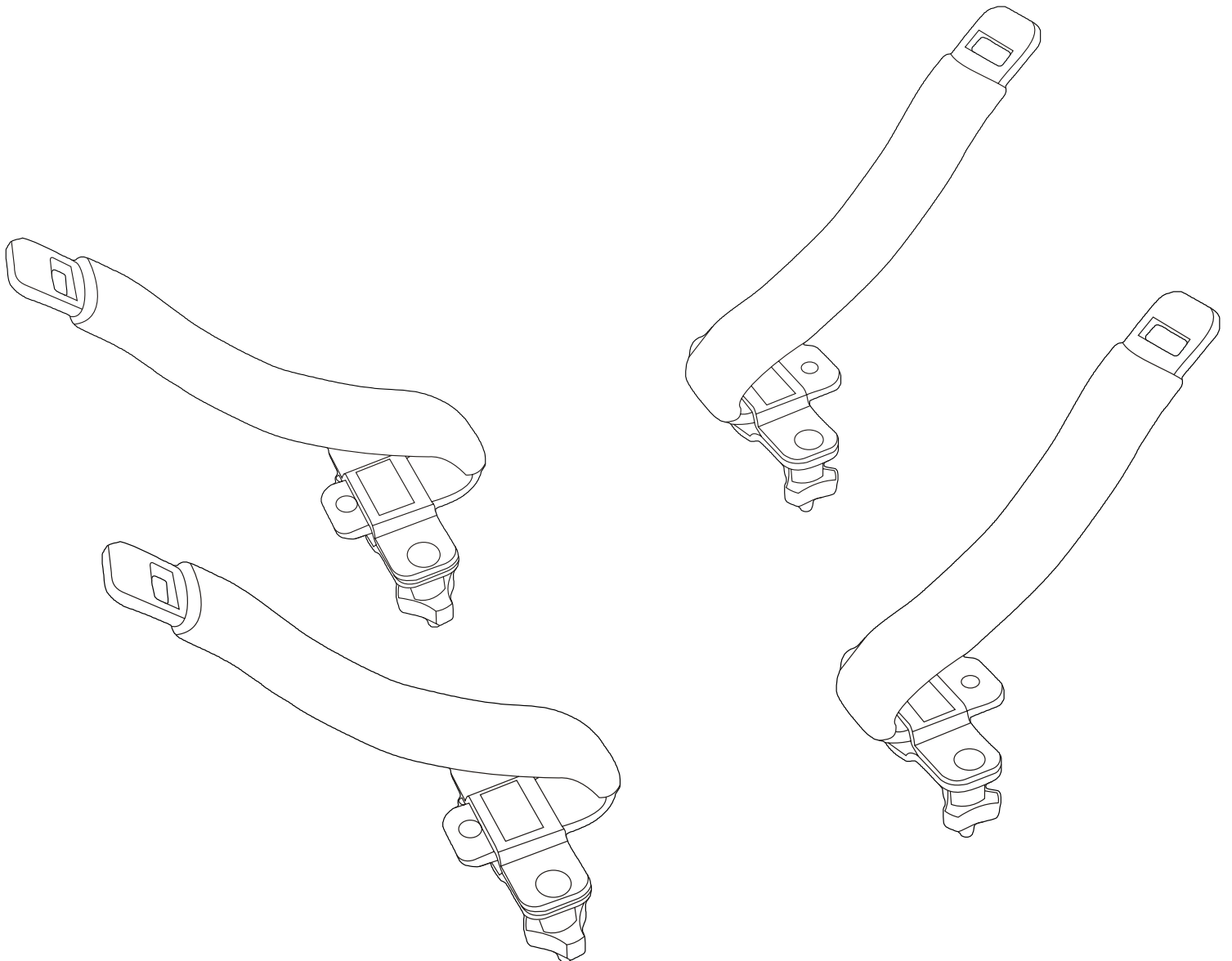

Kayak Roof Rack V Bars

Instructions



Thank You for purchasing a Lomo kayak rack.

It is extremely important that your kayak is secured firmly to the rack and that the rack is secured firmly to the roof of your car. If your kayak came off the roof of your car and hit someone at 60 mph it could severely injure or kill someone so please take great care in ensuring that the kayak is secured sufficiently well to keep it in place during the journey.

During a journey the kayak on your roof will encounter several different types of force that will all be trying to rip the kayak off your roof and we must ensure that we have secured the boat well enough to withstand these forces.

When you drive forwards into the wind the air will try to put the boat rearwards and off the back of the rack. It may also try to push the nose of the boat upwards.

When you brake sharply the weight of the kayak will push forwards and the kayak will try to fly off the front of the rack.

When you encounter a side wind the wind will try to blow the kayak sideways and, depending on the nature of the wind, may try to twist the kayak in a circular motion.

Larger boats such as sea kayaks will be affected more than smaller river kayaks as there is less surface area exposed to the wind.

To make sure your kayak is secured in position we must do the following:-

- 1) Make sure your roof rack is strong enough for the job and correctly attached to your car.
- 2) Make sure the kayak rack is securely attached to your roof rack and is not loose.
- 3) Make sure the kayak is securely strapped onto the rack
- 4) Use nose and tail ropes to give extra security

In The Box

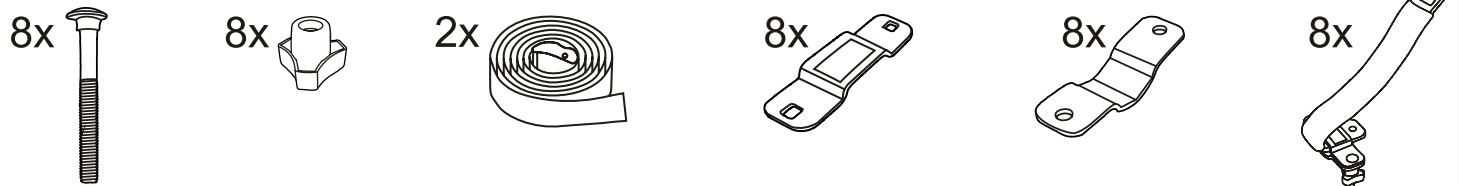

Step 1: Secure the rack to the roof rack.

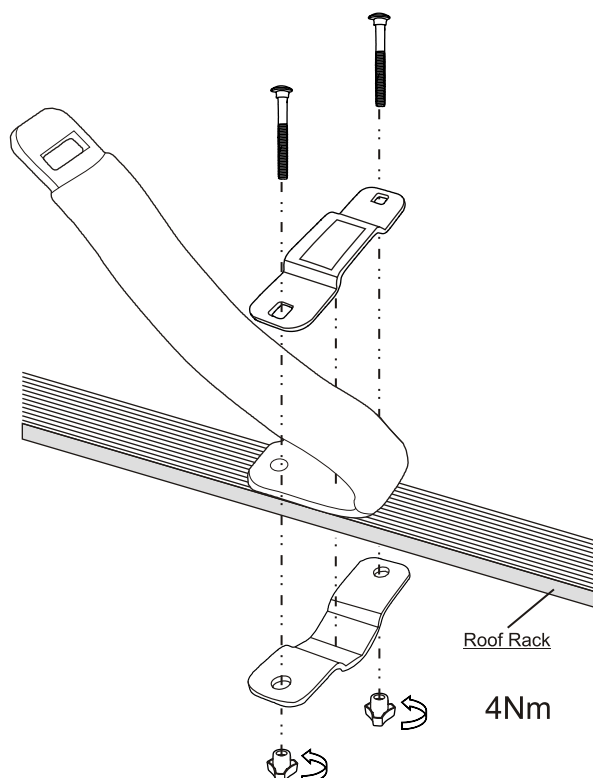
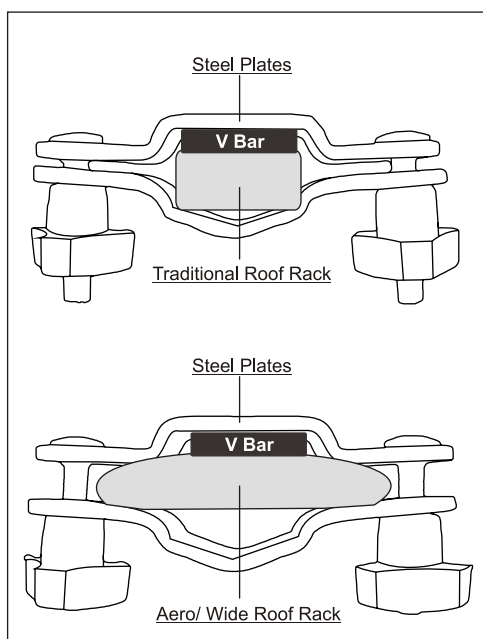

Step 2: Position the kayak on the rack.

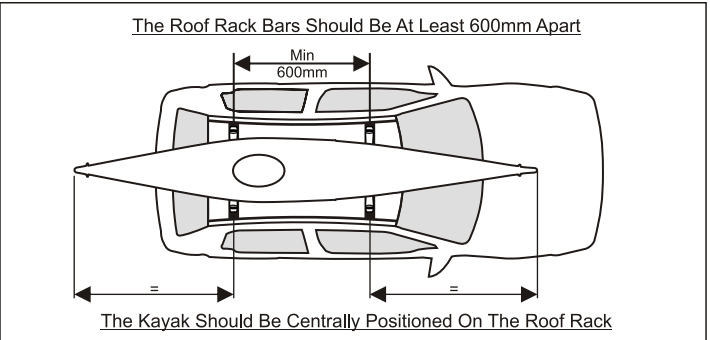
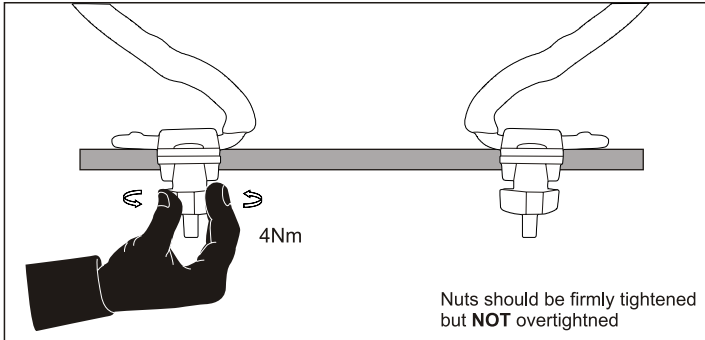

Step 3: Using the kayak straps, fasten the kayak to the rack.

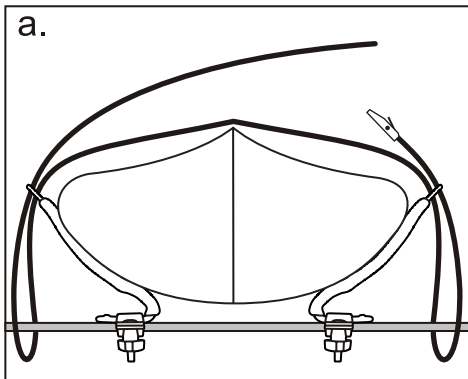

Thread the strap around the top of the rack.

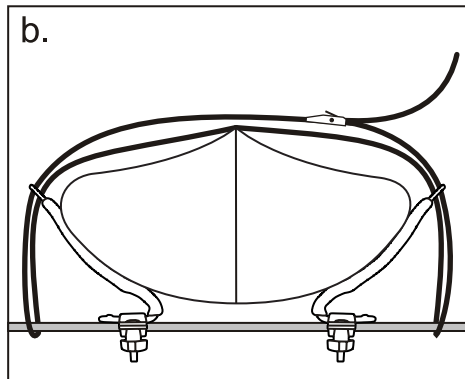

Pass the loose end round the roof rack bar. Then feed it through the cam buckle. (See Below)

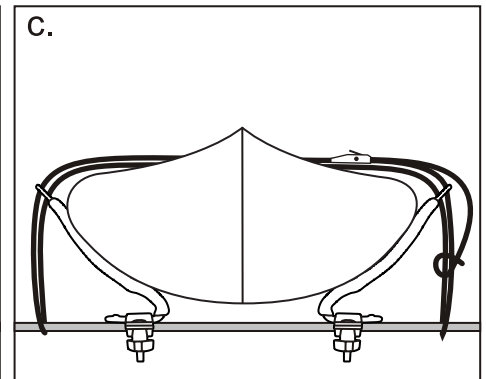

Pull the strap tight (but don't damage your boat by overtightening.) Tie the loose end down to prevent flapping in the wind.

Step 4: Use the nose and tail ropes to tie the kayak to strong points on your car such as a tow bar or towing eye.

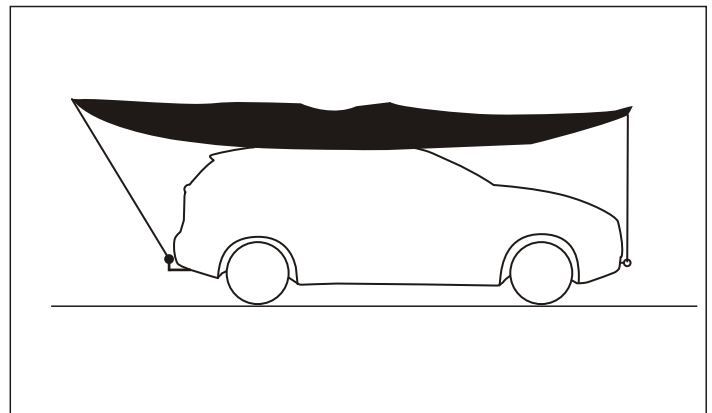
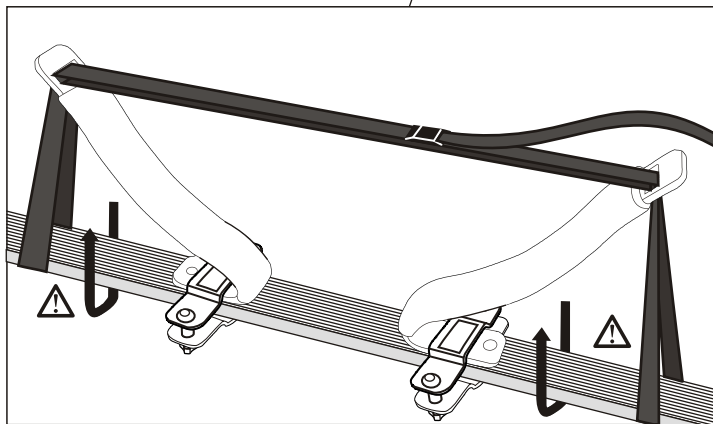

Safety Information

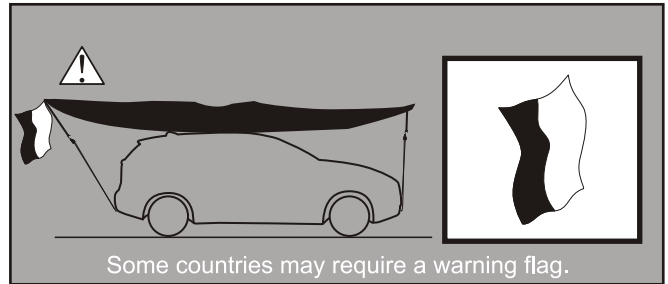
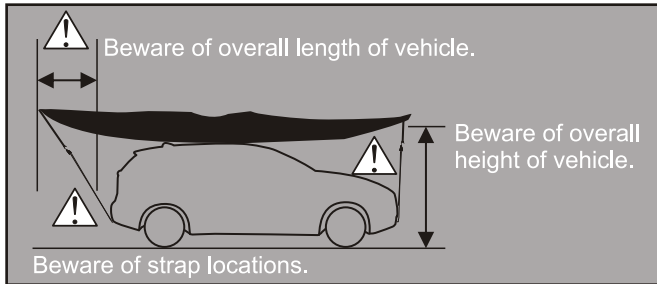
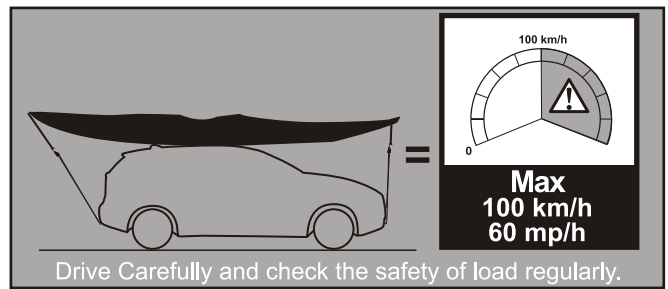
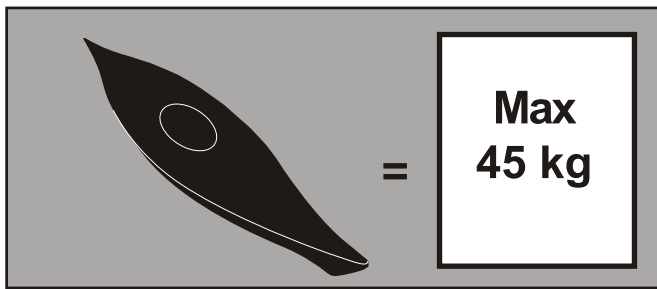

Notes

You may hear people giving different advice on whether or not you need to use nose and tail ropes to secure your kayak. At slow speed, with a small boat and low winds there is relatively low forces on the boat when compared to travelling at high speed with a larger boat in high winds. It's not however possible for us to give you a formula by which to calculate when you need to use nose and tail ropes. We also cant predict when a random gust of wind may appear and hugely increase the amount of force on the roof rack. So our advice is to always use nose and tail ropes to attach your boat safely to your roof.

Your kayak rack should be regularly checked for damage and signs of wear. If damage occurs to the paint and bare metal is exposed you should try to repaint this area to prevent rust and corrosion damaging the metal underneath.

Kayak straps and ropes should be regularly inspected to make sure that they have not become worn or damaged. During a journey, your load should be checked regularly to make sure that none of the straps or fasteners have loosened off and that the kayak , roof rack etc is still secure.

We recommend the use of a cockpit cover to make the kayak more streamlined and reduce drag.

Lomo Watersport
96 Hydepark Street G3 8BW Glasgow
admin@ewetsuits.com 01412217674
WWW.LOMO.CO.UK